

ACCROPODE™ II PRELIMINARY DESIGN GUIDELINES



Version V04 – Published in June 2024

Contents

1. Presentation.....	4
2. Glossary.....	5
3. Standard values - ACCROPODE™ II unit.....	6
4. Unit Shape and characteristics.....	7
5. Typical cross-section of a breakwater with a single-layer armour facing.....	8
6. Summary of the preliminary design.....	9
7. Data required.....	10
8. Preliminary sizing of the unit.....	11
9. Underlayer.....	16
10. Design guide table.....	18
11. Toe mound.....	19
12. Crest of the structure.....	24
13. Steps.....	25
14. Roundhead.....	26
15. Inner slope.....	27
16. Transitions.....	28
17. Quantity estimate.....	29
18. Physical scale modelling.....	30
19. Technical assistance.....	33
20. Calculator.....	37
21. Terms and conditions of use.....	38

1. Presentation

The design guidelines

This document is intended for designers of maritime structures who wish to use the ACCROPODE™ II technique for protecting rubble-mound breakwaters. These guidelines provide the key information required to perform the preliminary design of ACCROPODE™ II armour facings in accordance with the basic principles of the technique developed by SOGREAH (now ARTELIA) over more than 40 years.

Reliability through experience

CLI is the leader in breakwater protection technology using so-called “single-layer” systems. It has taken part in more than 380 projects in many countries involving ACCROPODE™, ECOPODE™, ACCROBERM™ and CORE-LOC™ units in a wide variety of conditions. It has acquired more than 70 years of experience in the construction of concrete armour facings for maritime breakwaters, starting with the TETRAPODE unit in 1953. 1981 saw the invention of the first single-layer unit, named the ACCROPODE™, which became the industry benchmark as the years went by. ACCROPODE™ units have been used in sizes ranging from 0.7m³ in areas with moderate waves to 28m³ to protect structures in Japan against the very strong waves of the Pacific Ocean. The ACCROPODE™ technique is far more than a mere concrete unit; it is a complete procedure guaranteeing that the characteristics developed by its inventor are achieved in full on the projects where it is applied. CLI’s specialist team provides technical assistance at all stages of the project. This assistance is intended for parties such as Owners, Engineers, physical scale modelling laboratories and, more particularly, construction contractors. To complete the package, CLI provides a compliance certificate issuing procedure enabling all parties to ensure that the breakwater is built in accordance with the ACCROPODE™ technology.

The ACCROPODE™ II unit

The experience acquired on a substantial number of projects led to the invention of a new generation of armour units. This new version retains the legendary qualities of its predecessor and, thanks to some changes to its shape and placing grid, further enhances stability under wave action while being faster and easier to place. The ACCROPODE™ II unit, which was launched on the market in 1999, thus improves the original concept by optimising its use.



Figure 1: ACCROPODE™ II units in Kuwait

2. Glossary

Symbol	Description	Unit
H	ACCROPODE™ II unit height	m
H _s	Significant wave height: In this document, H _s is considered to be equal to H _{1/3}	m
h	Water depth at the toe of the structure	m
V	ACCROPODE™ II unit volume	m ³
Δ	Relative density of the material considered $\Delta = (\rho_c - \rho_w)/\rho_w$	-
α	Slope angle	degrees
ρ _c	Concrete density	kg/m ³
ρ _r	Rockfill density	kg/m ³
ρ _w	Sea water density	kg/m ³
γ _f	Layer roughness coefficient	-
K _D	Unit stability coefficient	-
K _S	Shape coefficient	-
K _t	Layer or underlayer thickness coefficient	-
h _T	Water depth above the crest of the toe mound	m
T	ACCROPODE™ II armour thickness	m
Z _C	Crest level of the structure (above the last row of units)	m
Z _P	Level of the lower face of the concrete armour toe (below the first row)	m
D _{n50}	Nominal diameter of the elements	m
L	Scour apron width	m
D _H	Theoretical horizontal distance between the centres of gravity of two units	m
D _V	Distance parallel to the theoretical slope between the centres of gravity of two rows of units	m
D _n	Nominal diameter - single-layer armour unit	m
NLL	Nominal Lower Limit of the mass of the natural rockfill used for the underlayer	t
NUL	Nominal Upper Limit of the mass of the natural rockfill used for the underlayer	t
W ₅₀	Median weight of the rockfill	N
N	Number of armour units per unit area	U/m ²
N _s	Stability number	-
γ _h	Moist unit weight - single-layer armour unit	kN/m ³
γ _{sat}	Saturated unit weight - single-layer armour unit	kN/m ³
c	Interlocking cohesion - single-layer armour unit	kPa
φ	Angle of friction - single-layer armour unit	°

Table 1: Abbreviations and symbols

3. Standard values – ACCROPODE™ II unit

Unit volume	$V = 0.2926 H^2$
Nominal diameter	$D_n = V^{1/3}$
Shape coefficient	$K_S = 0.2926$
Stability coefficient	$Kd = 16$ and variable (cf. chapter 8)
Placing density	$\phi =$ Variable from 0.635 to 0.610
Layer porosity	Variable from 53.31% to 55.15%
Thickness coefficient of an ACCROPODE™ II unit layer	$K_{t1} = 1.36$
Thickness coefficient of an ACCROPODE™ II unit underlayer	$K_{t2} = 1.15$
Armour thickness	$T = 0.902 H$ or $T = K_{t1} \cdot D_n = 1.36 D_n$
Layer roughness coefficient	$\gamma_f = 0.44$ [cf. note 1]
Dry unit weight – single-layer armour unit	$\gamma_h = 15 \text{ kN/m}^3$ [cf. note 2]
Saturated unit weight – single-layer armour unit	$\gamma_{sat} = 19 \text{ kN/m}^3$ [cf. note 2]
Interlocking cohesion - single-layer armour unit	$c = 10 \text{ kPa}$ [cf. note 2]
Angle of friction - single-layer armour unit	$\varphi = 45^\circ$ [cf. note 2]

Table 2: Standard values for an ACCROPODE™ II single-layer armour facing

Note 1 – Source: Eurotop Manual Table 6.2 (values for a slope of 1:1.5)

Note 2 - Indicative values estimated by ARTELIA in order to model ACCROPODE™ II unit layers as “ground” elements

4. Unit shape and characteristics

The ACCROPODE™ II unit is a hexapod which fits into a cube, ensuring perfect interlocking in all directions by harnessing the forces of the neighbouring units according to a specific grid.

The bevels to which the sharp angles are cut make it easier to manage unit interlocking and prevent units becoming jammed during placing. This ensures simple, fast interlocking close to the optimal density. As a result, subsequent settlement at the construction site is limited in comparison with other types of unit.

The pyramids on each leg of the unit serve two purposes. They are designed to create more contacts between the units and increase their ability to harness the forces created by the neighbouring units. These are also sacrificial components that absorb the energy generated by impacts during unit placing.

The stability of the ACCROPODE™ II unit is partly due to its shape, which results from the experience gained with the first generation of ACCROPODE™ units. This stability is also induced by the placing technique, which harnesses the forces from the neighbouring units. This combination of features enables high levels of stability to be obtained.

Right - Figure 2: ACCROPODE™ II unit

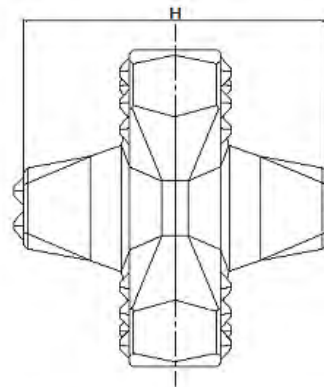
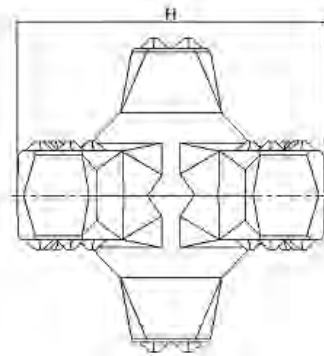
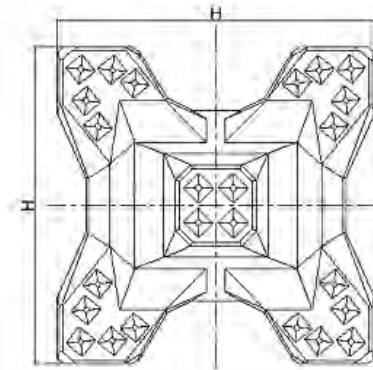

5. Typical cross-section of a breakwater with a single-layer armour facing

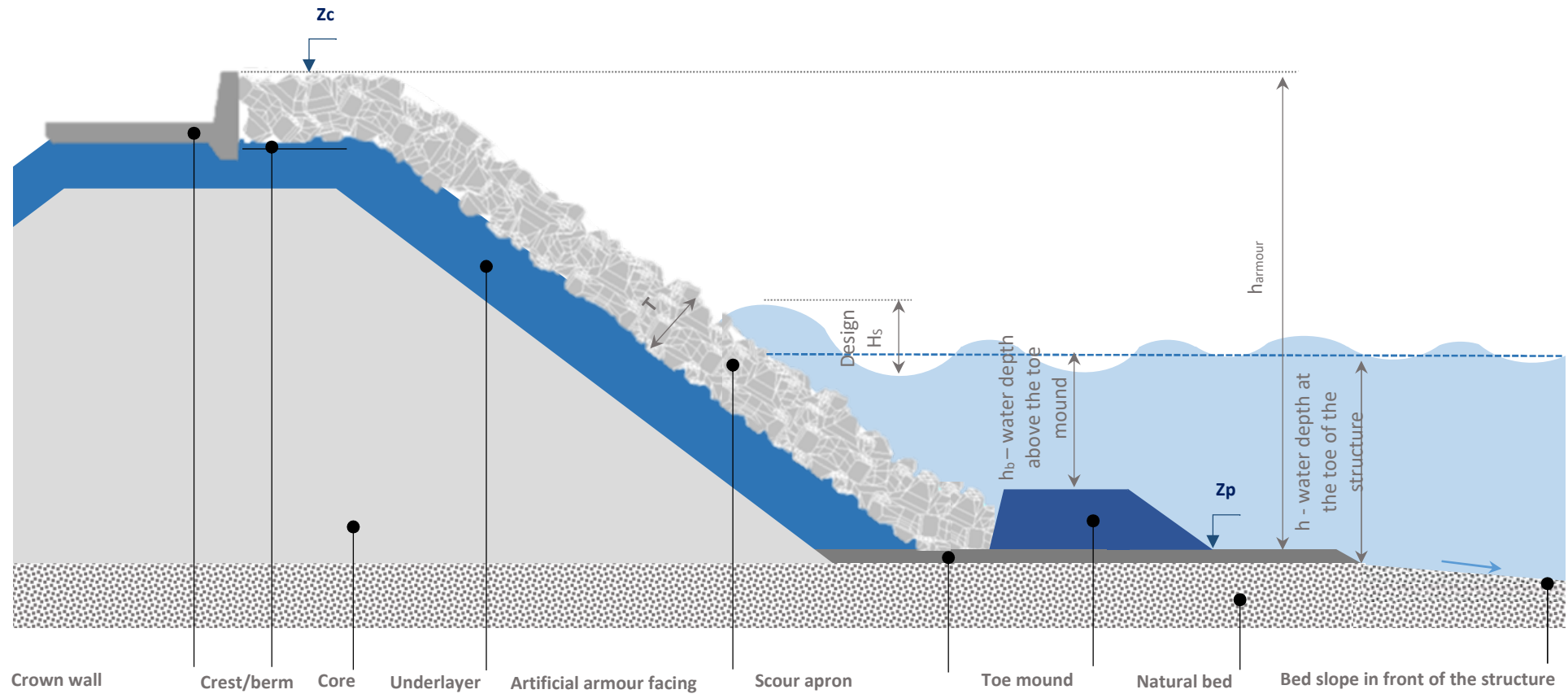

Figure 3: Typical cross-section of a breakwater with a single-layer armour facing

6. Summary of the preliminary design

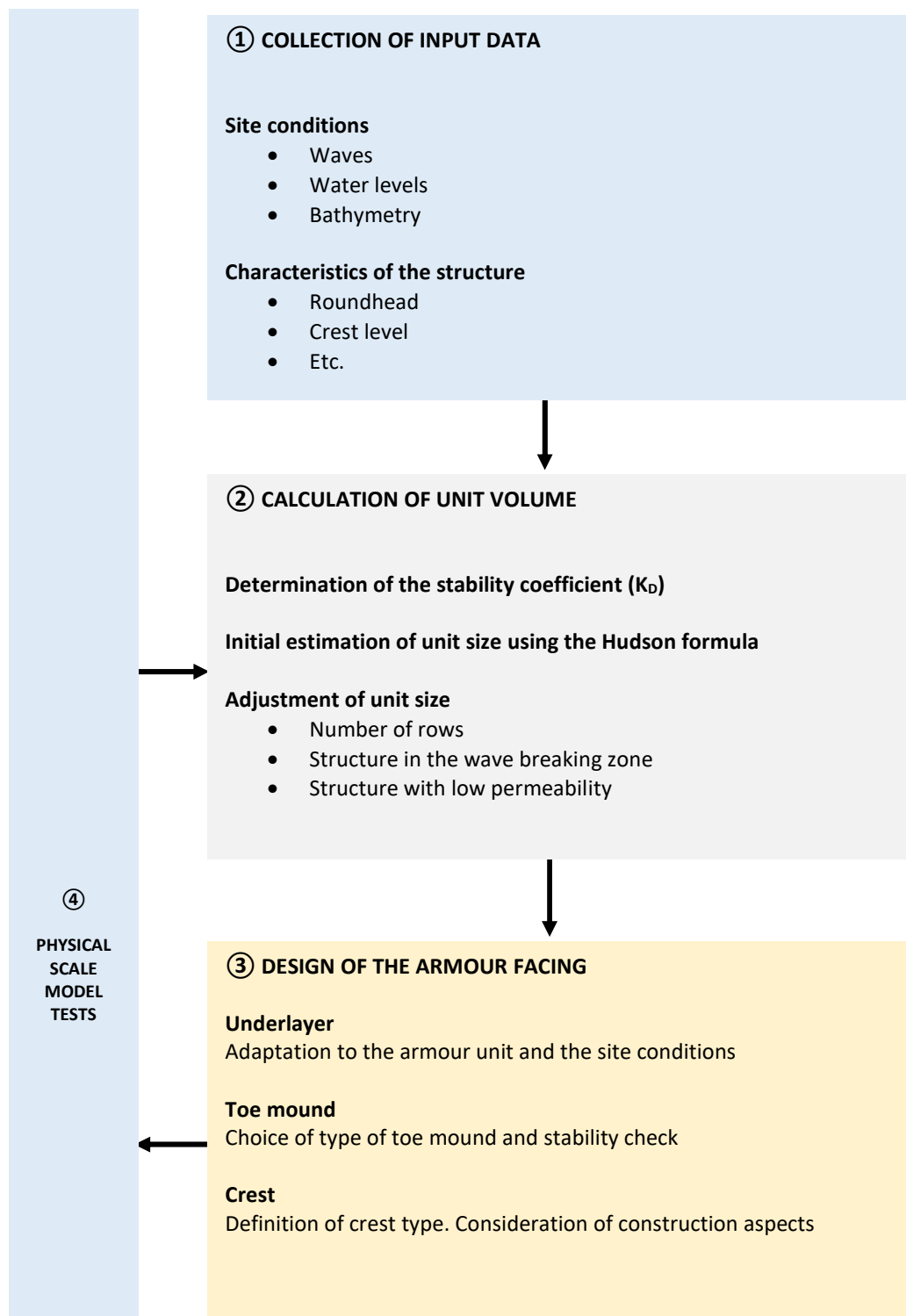

Figure 4: Outline of the preliminary design process

7. Data required

The information below is required for the preliminary design of the armour facing:

- Precise bathymetry in the vicinity of the structure;
- Reference wave;
- Water level: tide variations, influence of storms, levels induced by climate change;
- Wave breaking conditions;
- Minimum concrete density at the site;
- Sea water density;
- Rockfill density;
- Armour crest level z_c ;
- Foundation level of the first unit at the armour toe z_p ;
- Lifetime of the structure;
- Return period of design-critical events.

N.B.:

In the context of a preliminary design, the wave to be used is $H_{1/3}$. This corresponds to the “significant wave height, the average of the highest third of the waves, based on time domain analysis”, for the Hudson and Van der Meer formulae. The locations of wave points are selected by the structure designer depending on the site conditions.

Figure 5: Hydraulic shovel and lattice boom crawler crane during ACCROPODE™ II unit placing

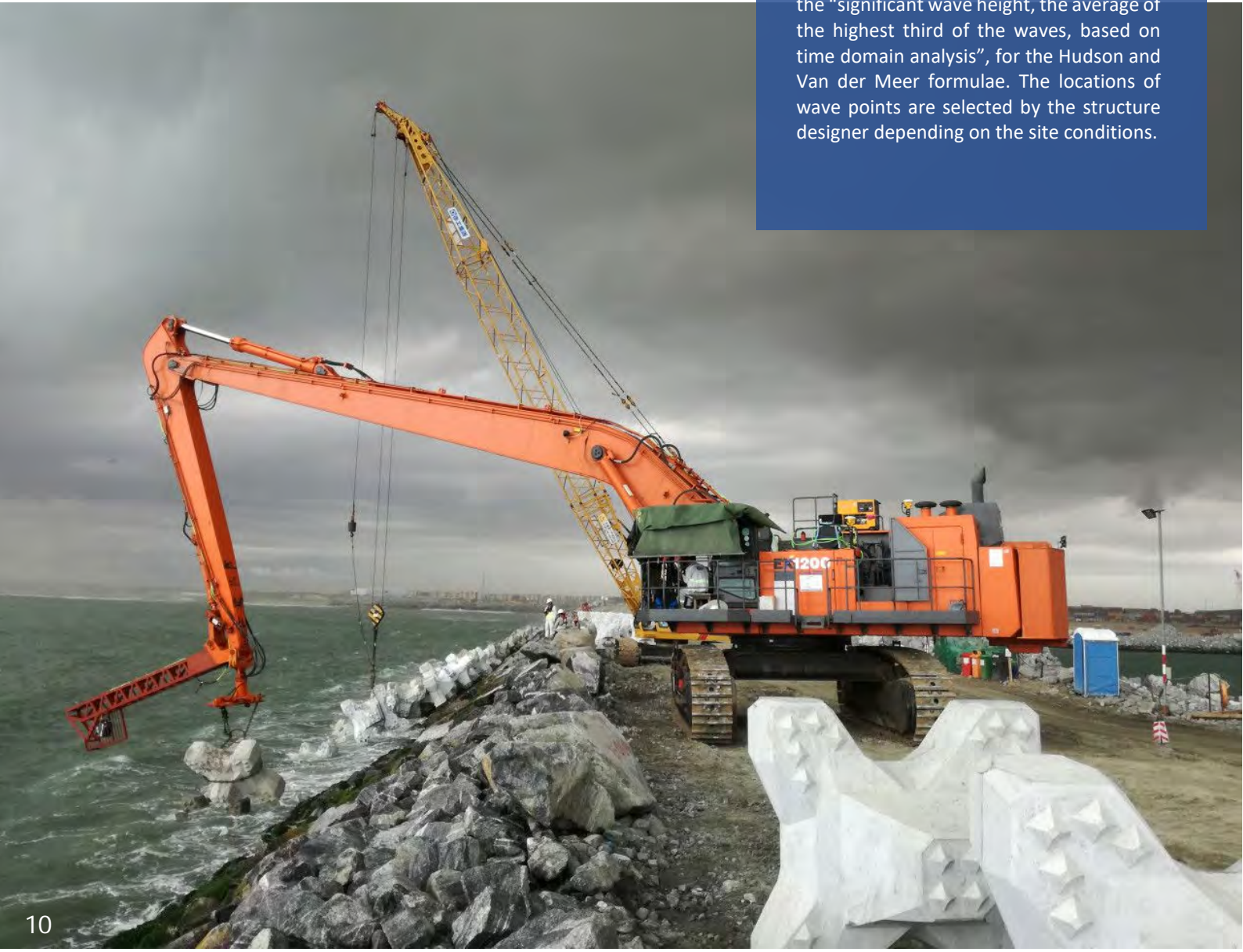

8. Preliminary sizing of the unit

The Hudson formula is commonly used for the preliminary sizing of armour units. It is simple and has benefited from extensive feedback. This method takes the design wave height into consideration, along with other factors that influence unit stability. The preliminary sizing of armour units is summarised in the diagram opposite.

Right - Figure 6: Diagram explaining the preliminary unit sizing process

Below - Figure 7: Breakwater with ACCROPODE™ II units - view from the pedestrian walkway on the crest – marina in Kuwait

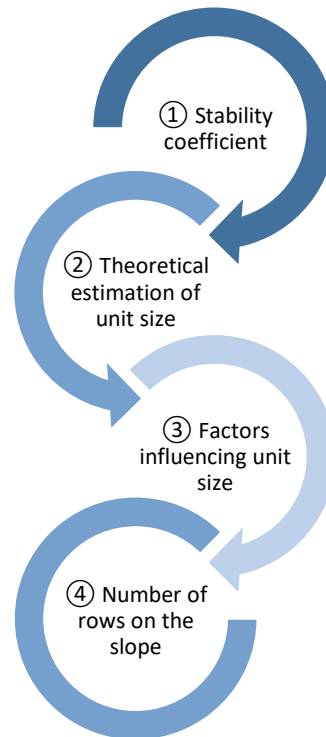

Stability coefficient

The first step is to estimate the stability coefficient value to be used, as this is factored into the Hudson formula. This coefficient may vary depending on the bed slope in front of the structure, the wave-breaking conditions, and the type of trunk section or bend/roundhead.

ON TRUNK SECTIONS

The unit stability coefficient depends, among other things, on the type of breaking wave. This breaking wave is itself influenced by the wave characteristics, the bathymetry and the water depth.

- For the case of a non-breaking wave, the K_D value used is that of a bed slope of less than 1%.
- For the case of a breaking wave, Figure 8 below gives an estimated K_D value to be used for sea bed slopes from 1 to 10%.
- With a bed slope percentage greater than 10% in front of the structure, the structure designer must use an even lower K_D value and perform physical scale model tests to specify the stability of the units. A conservative approach is strongly recommended.

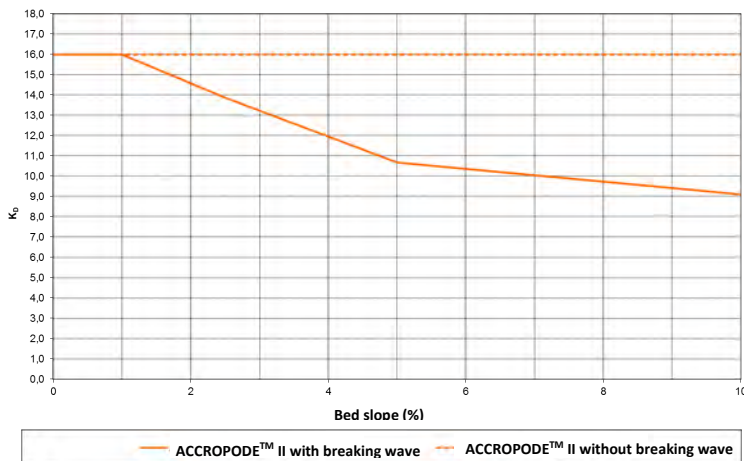

Figure 8: K_D values on a trunk section

ON ROUNDHEADS OR BENDS

On roundheads and bends, the stability coefficient must be reduced by 30% in order to account for the three-dimensional effects of wave action as well as the fact that unit interlocking is more difficult to obtain during the works.

As is the case on trunk sections, the stability coefficient is influenced by wave breaking.

For the case of a breaking wave, Figure 9 gives an estimated K_D value to be used on a bend or roundhead.

The following conditions are applied:

- For the case of a non-breaking wave, the K_D value used is that of a bed slope of less than 1%.
- For the case of a breaking wave, Figure 9 gives an estimated K_D value to be used on a bend or roundhead.
- With a bed slope steeper than 10% in front of the structure, the structure designer must use an even lower K_D value and perform physical scale model tests to validate the stability of the units. A conservative approach is strongly recommended.

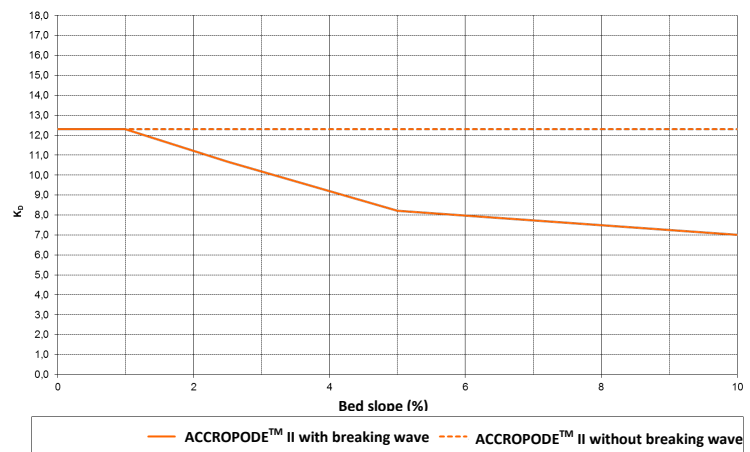

Figure 9: K_D values on a roundhead or bend



Figure 10: photograph of ACCROPODE™ unit placing using a crane mounted on a barge

Estimating unit size

Hudson formula

The size of the ACCROPODE™ II units is calculated using the Hudson formula, with a hydraulic stability coefficient that varies as indicated in the previous section.

On the right: Hudson formula modified so as to obtain the unit volume directly - Ref [1] CIRIA - CUR - 2009 Rock Manual section 5.2.2.2

$$V = \frac{H_s^3}{K_D \Delta^3 \cotan \alpha}$$

Where

V	ACCROPODE™ unit volume	m ³
H _s	Significant wave height (H _{1/3})	m
Δ	Concrete relative density (ρ _c - ρ _w)/ρ _w	kg/m ³
ρ _c	Concrete density	kg/m ³
ρ _w	Sea water density	kg/m ³
K _D	Hydraulic stability coefficient	[-]
cotan α	Cotangent of the slope angle (see notes below)	[-]

Notes

Generally speaking, slopes of 4:3 or 3:2 may be used. In the Hudson formula, it is preferable to use a slope of 4:3 (cotan(α) = 1.33). Gentler slopes lead to lower friction and interlocking forces, which are detrimental to unit stability.

The usual concrete density values range between 2,300 kg/m³ and 2,500 kg/m³. Outside this range, the hydraulic response may differ from that of a standard armour facing.

Factors influencing unit stability

Other factors must be considered in fine-tuning the preliminary design obtained using the Hudson formula. Table 3 below indicates the influential parameters that are encountered most frequently. There may be others specific to the individual work site.

SITUATION	EFFECTS	CORRECTION
Structure in the wave breaking zone	Frequent waves close to the design wave. Fatigue effect.	It is suggested to reduce the stability coefficient by 20%.
Oblique waves	The units tend to be more stable when wave attack is oblique.	Reducing the unit size is not recommended.
Armour slope is 3:2 or less	Unit interlocking is less effective.	In the Hudson formula, it is recommended to use a $\cot \alpha$ value equivalent to a slope of 4:3, i.e. 1.33. Stability tests are compulsory.
Low-crested structures¹	Significant action related to overtopping on the angle and crest lines.	Physical scale model checks must be carried out.
Breakwater with impermeable or low-permeability body	Risk of additional forces on the units, and of overtopping.	According to the work of <i>Burcharth et al.</i> , stability can decrease by 50% with a core composed of fine materials, and can decrease further with wave periods of $T_p > 15$ s. Reducing the stability coefficient by 50% is hence recommended on non-permeable structures.
Many rows of units on the slope	Risk of more significant cumulative settlement.	Increase the unit size or modify the toe mound in order to comply with the criteria recommended in table 4 below.

Table 3: Factors influencing unit stability

Note

¹According to [1] CIRIA-CUR-CETMEF Rock Manual, The use of rock in hydraulic engineering – 2009, section 5.2.2.1, a low-crested structure has a crest level above or below the still sea water level.

When several factors among those listed in table 3 are combined, they must be addressed with a conservative approach to be on the safe side. Less is known about combined effects, and they are difficult to control. In this case, the lowest stability coefficient K_D value must be selected and then reassessed with an increased safety factor left to the discretion of the structure designer. It is advisable to increase the size of the units. Physical scale model testing remains strongly recommended in all cases.

Number of rows on the slope

The number of rows on the slope must be limited in order to control any cumulative settlement arising due to normal rearrangement of the armour units. CLI therefore recommends the values given in table 4 opposite. These values are not mandatory but, should they be exceeded, CLI recommends oversizing the units in order to limit the stresses exerted on them by the design wave and, hence, to limit settlement.

ACCROPODE™ II unit size	Recommended maximum number of rows on the slope
Less than 4 m ³	22
4 to 8 m ³	20
8 to 16 m ³	18
More than 16 m ³	16

Table 4: Recommended maximum number of rows

To limit the number of rows, there are two possible solutions:

Increase the size of the units. While this solution slightly increases concrete consumption, it significantly reduces the number of units to be fabricated and placed. It also provides an additional safety factor.

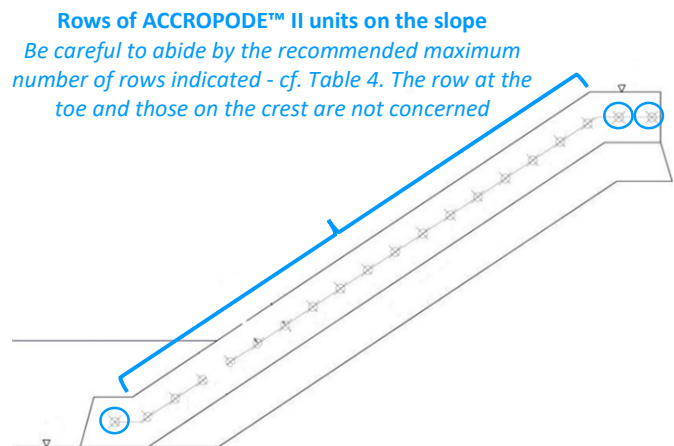

Figure 11: Schematic diagram - number of rows counted on the slope

Raise the foundation level of the armour toe (see Figure 12 opposite) to limit the number of rows of armour units. This type of change may have an impact on wave breaking. The stability of this foundation and the toe mound must be checked.

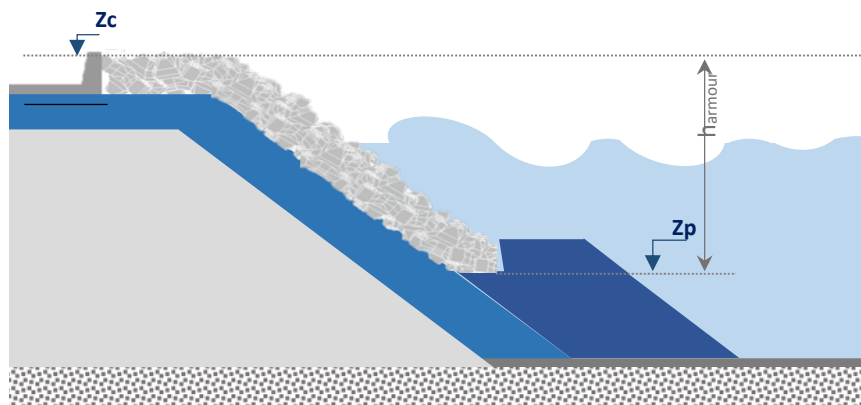

Figure 12: Schematic diagram of a cross-section of a breakwater with a raised toe foundation level.

9. Underlayer

Layout

Single-layer armour units are placed on an underlayer with specific properties. To guarantee a suitable base for the armour units, the rockfill forming the underlayer must be laid so as to:

- Achieve a roughness suited to the size of the armour units,
- Achieve a porosity that will absorb the wave energy correctly,
- Respect the filtration rules between the core and the armour facing.

The underlayer must comply with the rules governing the rockfill grading and shape given in the CIRIA – CUR 2009 Rock Manual.

Right - Figure 13: Photograph of an underlayer with broken faces - for the new deep-water terminal at the port of Kuantan (Malaysia) Port side.



Rockfill weight and geometry

Table 5 summarises the geometrical information on the rockfill to be used to build the underlayer.

Description	Limit values	Note
Rockfill weight	NUL and NLL - Ref [2]	Please refer to the recommendations given in the design table available on CLI's website www.concretelayer.com and below
Rockfill shape	$L+G/2E \leq 3$ and $L/E < 3$	L: the largest dimension G: the largest measurable dimension perpendicular to direction L E: the largest dimension perpendicular to the plane LG

Table 5: Rockfill of the underlayer

The nominal limits (NLL and NUL) of natural rockfill for the underlayer must be between 7% [NLL] and 14% [NUL] of the armour unit mass (see Ref [1] section 5.2.2.3). However, a tolerance may be applied to optimise the number of rockfill categories required for a given project. (see Table 6)

The grading must not be too narrow (as this leads to difficulties during construction) or too wide (as this reduces filter porosity and poses a potential risk of segregation). To ensure an evenly distributed grading, the following relation should preferably be used: $2 \leq NUL/NLL \leq 3$ (see Ref [1] section 5.5.5.3 and Ref [2]). The rockfill must have angular shapes and a large number of broken faces.



Figure 14: Photograph of an underlayer

Thickness of the underlayer

The thickness of this underlayer is calculated as follows:

$$e = n \cdot K_{t2} \cdot D_{n50}$$

Where

e: thickness of the underlayer;

n: number of layers;

K_{t2}: underlayer coefficient; for ACCROPODE™II, *K_{t2}*=1.15

D_{n50}: nominal diameter of the underlayer rockfill

In the event that natural quarry rockfill is not available, artificial rockfill such as shattered concrete or other rock types can be used. Specific studies will have to be performed to demonstrate that the proposed substitutes are equivalent to natural quarry rockfill.

Note concerning construction of the underlayer

It is important to bear in mind that the underlayer must be constructed in accordance with the placing tolerances related to the ACCROPODE™ II technique; in other words, the permissible tolerance at any point of the underlayer is +/- H/6 with respect to the theoretical profile, H being the height of the ACCROPODE™ II unit considered (this measurement is taken vertically).

10. Design Guide Table

below and can be consulted on CLI's website [https://www.concretelayer.com]. It is advisable to refer to the version available on the website, as this contains the most recent updates.



ACCROPODE™ II - ECOPODE™ Design Guide Table

The ECOPODE™ unit size is limited to 10m³

Unit Volume (m ³)	$V = 0.2926H^3$		1.0	2.0	3.0	4.0	5.0	6.0	8.0	10.0	12.0	14.0	16.0	18.0	20.0	22.0	24.0	28.0	
Unit Height (m)	$H = (V/0.2926)^{1/3}$		1.51	1.90	2.17	2.39	2.58	2.74	3.01	3.25	3.45	3.63	3.80	3.95	4.09	4.22	4.34	4.57	
Equivalent Cube Size (m)	$D_n = V^{1/3}$		1.00	1.26	1.44	1.59	1.71	1.82	2.00	2.15	2.29	2.41	2.52	2.62	2.71	2.80	2.88	3.04	
Armour Thickness (m)	$T = 1.36 D_n$		1.36	1.71	1.96	2.16	2.33	2.47	2.72	2.93	3.11	3.28	3.43	3.56	3.69	3.81	3.92	4.13	
Armour concrete consumption and coverage	Packing density ϕ (-)		0.635	0.635	0.635	0.633	0.631	0.629	0.625	0.622	0.618	0.614	0.610	0.610	0.610	0.610	0.610	0.610	0.610
	Consumption (m ³ /m ²)		0.635	0.800	0.916	1.005	1.079	1.143	1.251	1.339	1.414	1.479	1.537	1.599	1.656	1.709	1.760	1.852	
	Number of units (u/m ²)		0.635	0.400	0.305	0.251	0.216	0.191	0.156	0.134	0.118	0.106	0.096	0.089	0.083	0.078	0.073	0.066	
	Porosity (%)		53.31	53.31	53.31	53.45	53.59	53.73	54.02	54.30	54.58	54.86	55.15	55.15	55.15	55.15	55.15	55.15	55.15
Filter stone underlayer to meet the following requirement NUL/NLL < 3.0	NLL (tons)	Standard	0.17	0.34	0.50	0.67	0.84	1.01	1.34	1.68	2.02	2.35	2.69	3.02	3.36	3.70	4.03	4.70	
		Min/Max*	0.1 0.2	0.2 0.4	0.4 0.7	0.5 0.9	0.6 1.1	0.7 1.3	0.9 1.7	1.2 2.2	1.4 2.6	1.6 3.1	1.9 3.5	2.1 3.9	2.4 4.4	2.6 4.8	2.8 5.2	3.3 6.1	
	NUL (tons)	Standard	0.34	0.67	1.01	1.34	1.68	2.02	2.69	3.36	4.03	4.70	5.38	6.05	6.72	7.39	8.06	9.41	
		Min/Max*	0.2 0.4	0.5 0.9	0.7 1.3	0.9 1.7	1.2 2.2	1.4 2.6	1.9 3.5	2.4 4.4	2.8 5.2	3.3 6.1	3.8 7.0	4.2 7.9	4.7 8.7	5.2 9.6	5.6 10.5	6.6 12.2	
	Thickness (m) for standard NLL&NUL Specific density 2,6 t/m ³	Kt=1,15	1.06	1.33	1.52	1.68	1.81	1.92	2.11	2.28	2.42	2.55	2.66	2.77	2.87	2.96	3.05	3.21	
		Kt=0.9*	0.83	1.04	1.19	1.31	1.41	1.50	1.65	1.78	1.89	1.99	2.08	2.17	2.24	2.32	2.38	2.51	

This table is to be used together with the note "Additional essential information regarding the tables" here appended.

Kt=0.9* : minimum value that depend on rocks shape and placing methodologies. For primary armour directly exposed to the waves effects kt=1.15 is to be used.

Table 6: Extract from the ACCROPODE™ II and ECOPODE™ Design Guide Table

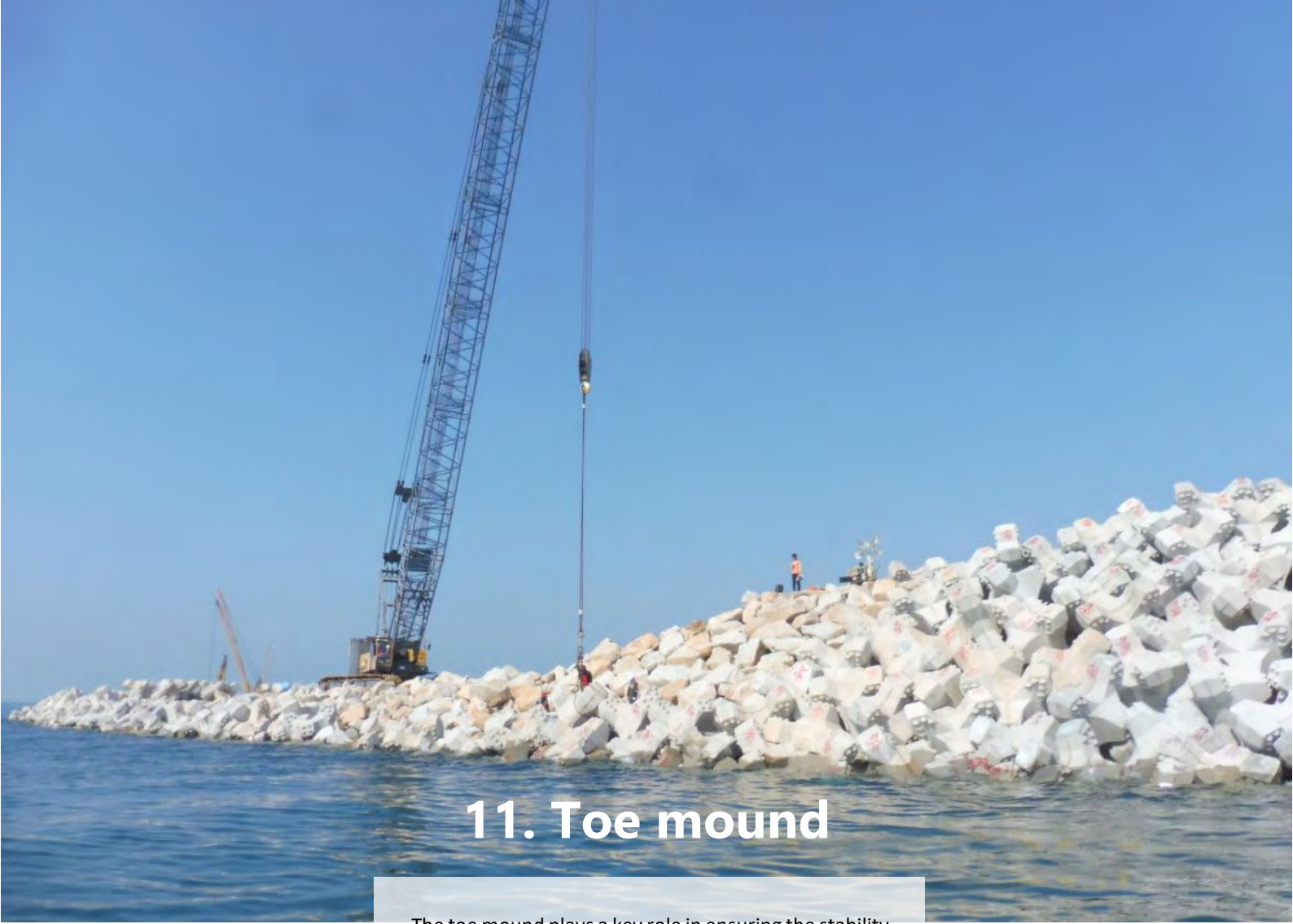

11. Toe mound

The toe mound plays a key role in ensuring the stability of armour facings. The designer must bear in mind that the toe mound must be constructible and that any difficulties related to its construction (depth, nature of the seabed, bed slope, waves) must not undermine the stability of the structure;

Figure 15: Photographs - construction of the detached breakwater for the new deep-water terminal in the port of Kuantan

Figure 16: rockfill toe mound and V-shaped trench



Types of toe mound

ACCROPODE™ TOE MOUND

The ACCROPODE™ toe mound is the basic solution to ensure good stability in the majority of cases. It is the most widely used, because it is the easiest to construct. It consists of a row of armour units placed on a scour apron and reinforced by a double layer of rockfill so as to guarantee the stability of the first unit. The thickness of the rockfill must not exceed that of the single-layer armour units. The thickness of the toe mound should not normally be less than two-thirds of the unit height.

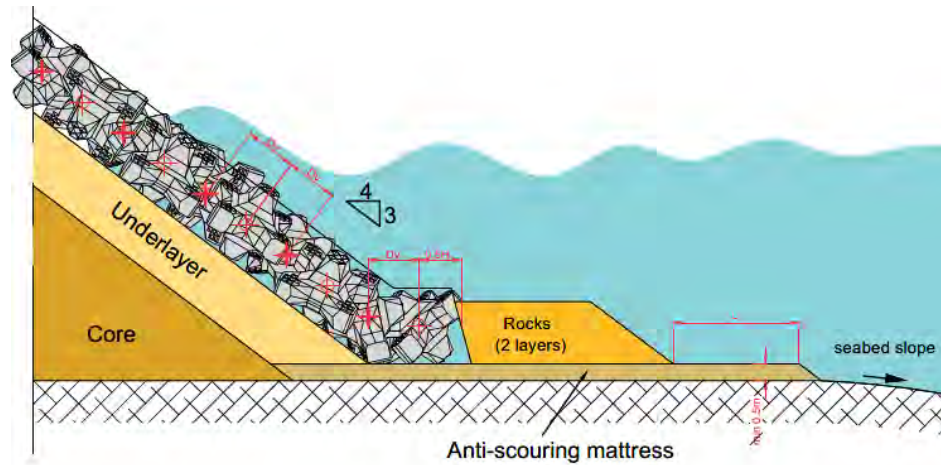

TYPE I EMBEDDED TOE MOUND: LOOSE SOIL AND ROCK

This type of toe mound is usually recommended in shallow water when it is difficult to stabilise the rockfill or the scour protection materials sufficiently. The configuration is similar to the previous one, but simply laid in a trench excavated at the toe of the structure. In case of scouring risk or soil punching, additional under-layer is to be placed underneath the first ACCROPODE™ unit

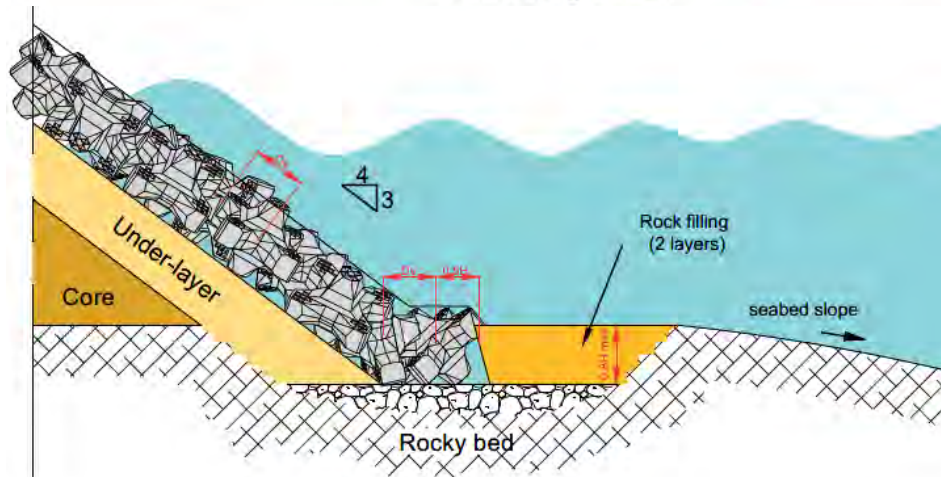

TYPE II EMBEDDED TOE MOUND: ROCK

This type of toe mound is generally used in the most exposed areas of the structure, where conventional toe mounds cannot withstand the wave action. The units are placed in a V-shaped trench excavated into the rock. Since this type of toe mound is more difficult to build, it is only used in the most severe cases. It must be built with great care. Its quality depends greatly on the nature and dip of the rock.

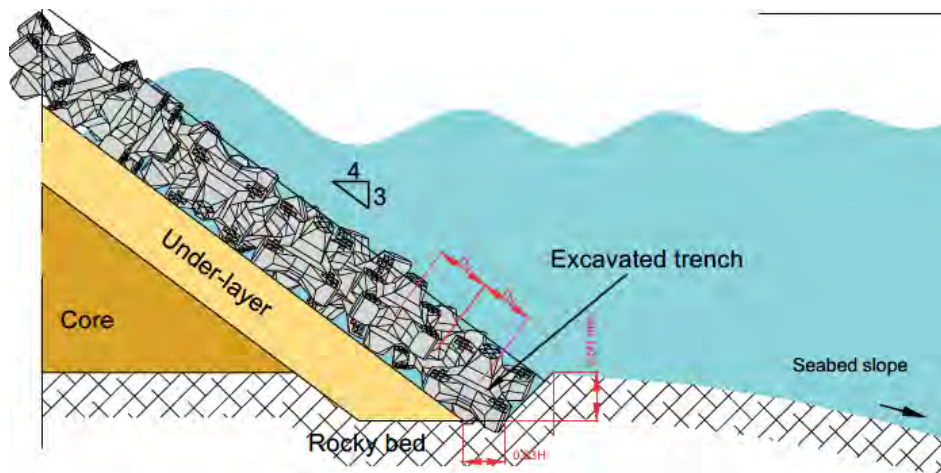

ROCKFILL TOE MOUND: V-SHAPED TRENCH

This toe mound is rarely used, because it is much more complex and costly to build. The alternative types of toe mound presented above avoid this complexity. This toe mound is generally built in good visibility conditions, in shallow water (less than 2 m), and with rockfill of less than 2 T. The use of a hydraulic shovel is virtually unavoidable. See figure 16.

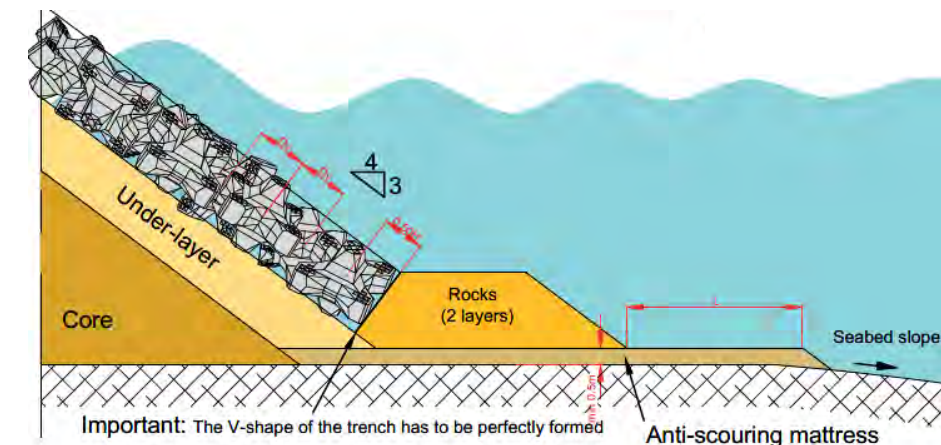

Opposite:

Figure 17: ACCROPODE™II toe mound

Figure 18: Type I embedded toe mound - loose soil and rock

Figure 19: Type II embedded toe mound - rock

Figure 20: Rockfill toe mound in V-shaped trench

ACCROBERM™ I AND II TOE UNITS

To provide a more reliable and more economical solution, two types of toe unit have been developed. Both of these solutions must be used in the specific conditions describe below.

ACCROBERM™ I

This unit replaces the first row of ACCROPODE™ II units and does away with the double layer of rockfill that serves as a toe berm in a standard toe mound. Therefore it significantly reduces the footprint of the structure on the bed and the quantity of materials to be used. It overcomes the difficulties of stabilising the rockfill in conventional toe mounds.

This unit is particularly suitable when the bed slopes opposite the structure are between 0 and 5%. For a steeper bed slope, this unit may not be sufficient to stabilise the toe. In this case an embedded toe mound will be required.

The weight of the unit is the same as that of the ACCROPODE™ II unit that it supports. The grid is also determined according to that of the ACCROPODE™ II unit that it supports.

The methodology for placing the first row of ACCROPODE™ II armour units is adapted in order to optimise load transfer between the facing and its toe mound. This first row may be placed in a systematic manner and a similar orientation.

ACCROBERM™ II

This unit is used in an eco-design approach. It is positioned as a reinforcing “toe berm” as a substitute for rockfill. The centre of this ring-shaped unit is filled with rockfill of a specific size depending on the targeted species and their habitats and development stages.

It substantially reduces the footprint of the structure and creates a new ecosystem. The larvae captured by the textured surface of the units find a suitable substrate on which to grow and develop in a protected area at the toe of the structure. The size of the rockfill placed inside the ACCROBERM™ II unit is adjusted so as to create cavities of varying dimensions to suit the targeted species. Other eco-design and filling methods can also be used with this unit.

The size of the ACCROBERM™ II units is determined according to the armour unit grid. It is hence advisable to contact CLI to determine the most suitable size.

Below:

Figure 21: 3D view - ACCROBERM™ I placement

Figure 22: ACCROBERM™ I unit in toe position

Figure 23: 3D view - ACCROBERM™ II placement

Figure 24: ACCROBERM™ II unit in toe berm position

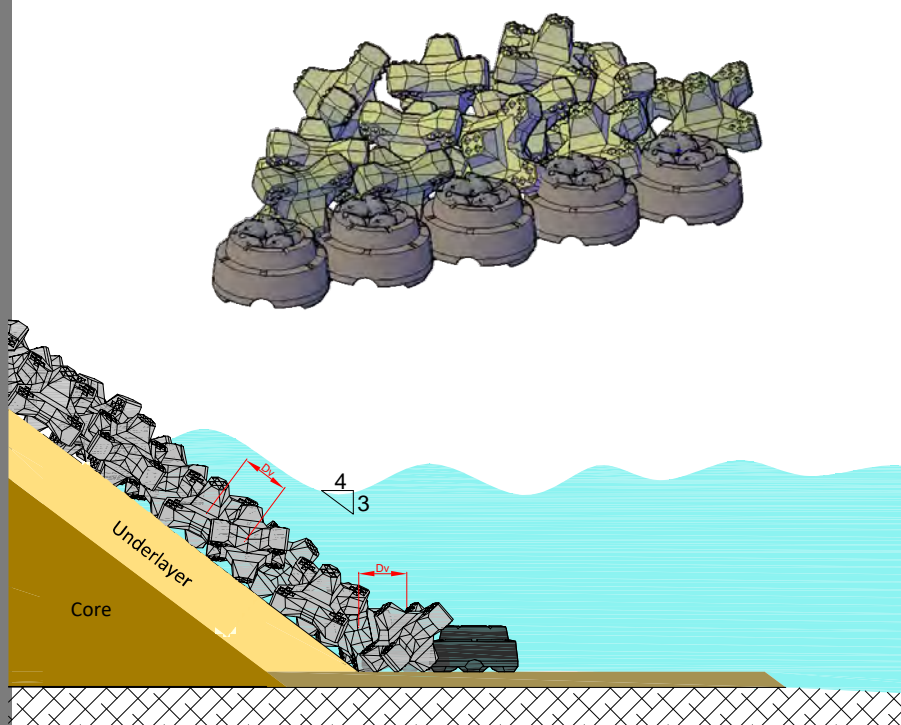
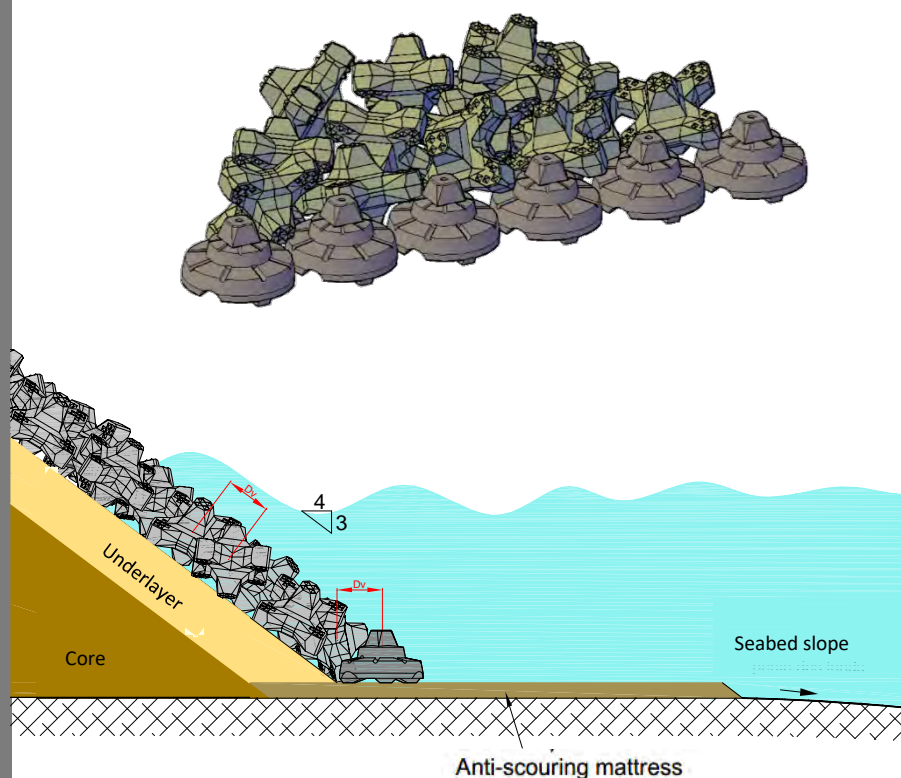

General approach to toe mound depth

Whenever possible, the crest of the toe mound (h_t) on the seaward side is generally at a minimum depth of $1.5H_s$ below low water. Ref [1] section 6.1.4.2.

Detailed information on rockfill sizing and toe mound position are given in section 5.2.2.9 of the Rock Manual Ref [1].

For structures in shallow water of $H_s < h_T < 1.1 H_s$, toe mounds of the embedded type are strongly recommended.

On the harbour side, the toe mound depth depends on the wave disturbance inside the basin and the scale of overtopping (Ref [1] section 6.1.4.2). It is essential to complement this initial approach with physical scale model tests.

Right - Figure 25: photograph of a breakwater under construction





Toe mound stability

When the toe mound is composed of rockfill, it is important to bear in mind that the stability of the rockfill is vital to the overall stability and durability of the armour facing. This rockfill must be stable and not be remodelled by waves in the design conditions.

The toe mound must guarantee that the armour facing remains properly wedged throughout the working life of the structure.

The rockfill must not be thrown onto the armour facing (risk of armour units breaking).

It must guarantee protection against scour when necessary.

The use of strict stability criteria is strongly recommended, such as a maximum damage number $N_{od} = 0.5$. It must be borne in mind that the minimum width must be $3 \times D_{n50}$ in the case of a standard toe mound or a so-called rockfill toe mound.

The formula of Van Der Meer et al (1995), given below, is commonly used for the preliminary design of the toe mound, but this initial approach must be complemented by physical scale modelling.

$$W_{50} = \left(\frac{H_s}{(2 + 6.2 (h_b/h)^{2.7}) N_{od}^{0.15} \Delta} \right)^3 \rho_r$$

Ref [1] section 5.2.2.9

- W_{50} : Median weight of the rockfill
- h : water depth at the toe of the structure
- h_b : water depth above the toe mound
- N_{od} : Damage number
(number of units displaced by a distance D_n)
 - ✓ = 0.5 start of damage
 - ✓ = 2 slight flattening
 - ✓ = 4 toe mound completely flattened
- Δ : Relative density of the rockfill
- ρ_w : Sea water density
- ρ_r : Rockfill density

Left - Figure 26: ACCROPODE™ II units on a breakwater

12. Crest of the structure

The type, level and width of the breakwater crest are generally defined by the following parameters:

- Overtopping rate, in accordance with the design criteria and, in particular, the purpose of the structure
- Whether or not the crest of the structure must be made accessible
- Constructional aspects enabling the project costs to be optimised.

Generally speaking the following minimum values are adopted for the width of a berm made of artificial armour units:

- $3 \times D_n$ when there is crown wall
- $2 \times D_n$ when there is rockfill behind the last unit
- $3 \times D_n$ when the crest is completely covered

With $D_n = V^{1/3}$ for one ACCROPODE™ II unit

These principles ensure that the units are sufficiently interlocked with each other and with the crown wall. Below this limit, it is still feasible to place the units but implementation becomes more difficult. On the other hand, only having a single row of units on the crest against a crown wall is strongly discouraged. There is a risk that this single row will not be blocked correctly between the slope and the wall. Special attention must be paid to low-crested breakwaters (crest level less than a height H_s from the design maximum sea water level), because armour units placed on a horizontal surface are less able to interlock with each other. It is hence recommended to increase the unit weight of the units and to conduct physical scale model tests in order to determine their stability (Ref [1] section 5.2.2.4). Moreover, with a view to maintaining the future structure and its armour facing, provision for an access road is recommended. If an access road cannot be built to carry out maintenance on the structure, this work can potentially be done from the sea.

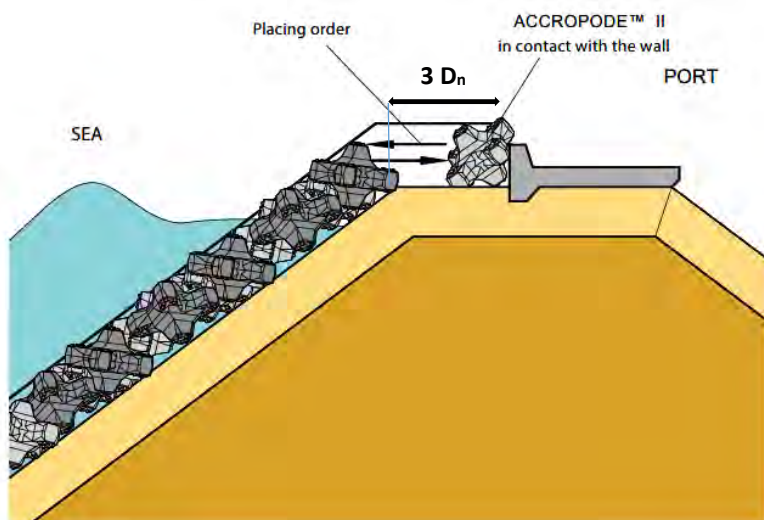

Figure 27: Example of a crest with a crown wall

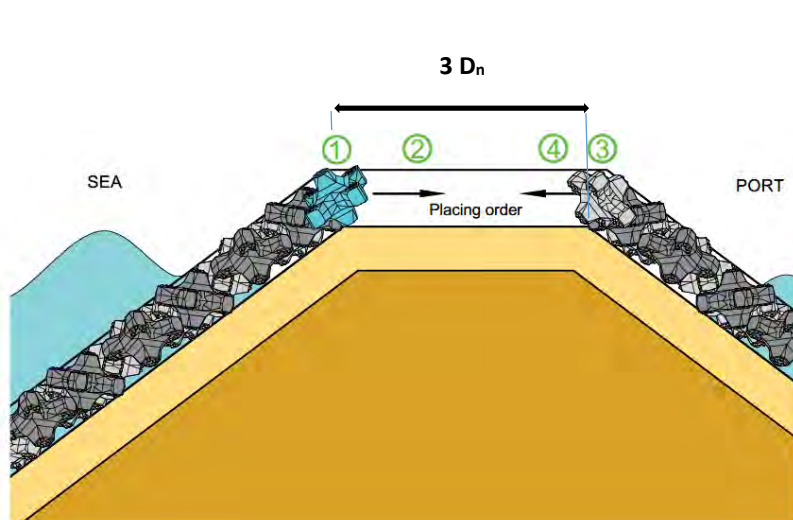

Figure 28: Example of a completely covered crest

13. Steps



Steps can be built into the armour facing. In the absence of a crest slab or access path, steps can provide access in order to maintain equipment (such as lighthouses, lamps, etc.).

Steps of this type must be positioned at the least exposed points of the breakwater. They should preferably be positioned in a calm area such as the inner slope, and not close to the roundhead.

The steps must be designed and built in accordance with local regulations.

*Left, opposite:
Figure 29 & Figure 30:
Photographs of the reinforced
concrete access steps*

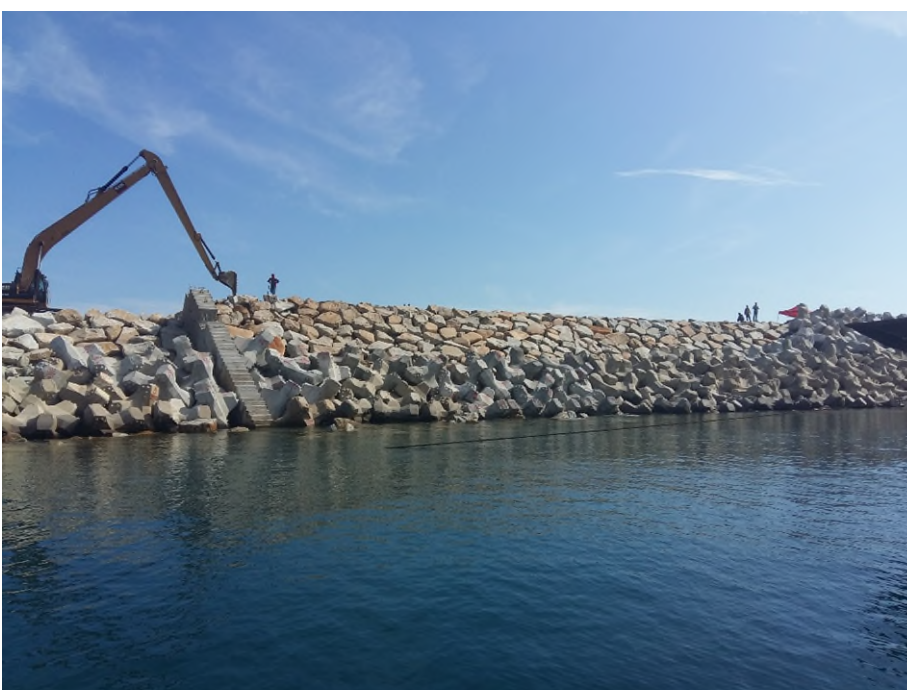

14. Roundhead

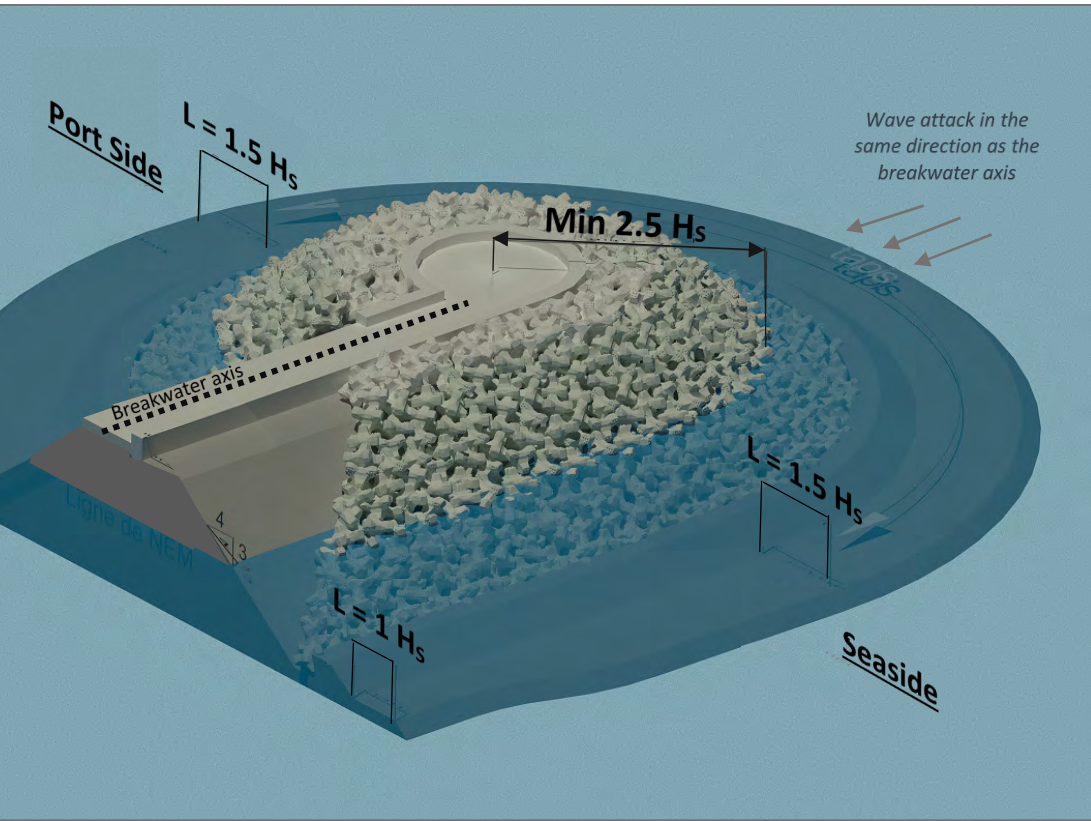

The roundhead is generally the most exposed part of the structure, owing to wave diffraction and overtopping. Interlocking of the units protecting this section of the breakwater is more difficult on account of its conical shape, so particular attention must be paid to this stage of placing. The design criteria must include an additional safety margin.

The radius of the roundhead must be at least 2.5 times the design wave height (the radius is measured horizontally from the centre of the roundhead to the outer side of the armour facing at the maximum sea water level considered for the project).

If wave attack occurs in the same direction as the breakwater axis, it is advisable to adopt a minimum roundhead radius of three times the design H_s or more, measured at sea level.

Left, opposite:

Figure 31: 3D view of a roundhead

Figure 32: Photograph of the roundhead on the project to extend the Port of Constanta in Romania



15. Inner slope

The main parameters for designing the armour facing of the breakwater inner slope are defined by:

- The water volumes overtopping the structure
- Wave disturbance inside the harbour basin (diffracted, reflected or incident waves, wind)
- Transmission of waves through the breakwater

There is no specific formula for sizing the single-layer armour facing on the inner side of the breakwater. The Hudson formula can be used for an initial approach if waves penetrate inside the harbour, but its limits will soon become apparent. Given the effects listed above, a physical scale modelling approach is preferable. Special attention must be paid during these tests to the toe mound on the inner side and to the consequences of overtopping.

Laboratory physical scale models will be required to determine the stability of this inner slope.

Below - Figure 33: Photograph of a breakwater with ACCROPODE™ II units in Aberdeen (Scotland)



16. Transitions

Transitions between different unit sizes/types or with rockfill are specific points that require special attention, because they result in a grid loss in the armour facing which must be considered as a critical point.

First of all, positioning these transitions in places that are critical in terms of wave action (roundhead and bends) is strongly discouraged. Physical model tests can help to locate the wave concentration zones, in order to avoid position transitions elsewhere.

A transition between units must be made along a line at an angle of 45° over the slope height. The larger units must be placed below the smaller ones. Whenever possible, the difference in unit volumes must not exceed 30% in order to avoid differences in armour thickness. When the differences in armour thickness are small (less than $H/6$), it is preferable to align the sections of the underlayer. When the differences exceed $H/6$, it is preferable to consult CLI.

Whenever possible, a transition between units should also be followed by a change in underlayer size. It is also possible to make transitions between two-layer and single-layer units. It is preferable to align the outer armour facings to avoid step-like effects between the units.

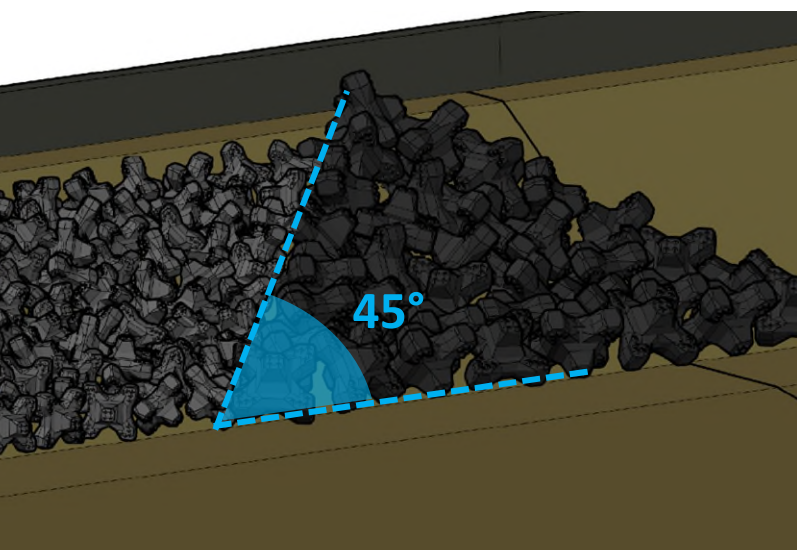

Figure 34: Transition between two different ACCROPODE™ II unit sizes



Figure 35: Close-up of the transition in Figure 34

- The transition is made at 45°
- The smaller units are supported by the larger ones
- Units of different sizes must be interlocked carefully
- While placing the units, pay attention not to create loose interlocking
- Adapt the grid to the transition (according to the placing drawing)
- Differences in thickness between the two armour facings should be avoided, by adapting the underlayer.
- Limit differences between two unit sizes to 30%

17. Quantity estimate

Stages

The conventional method for performing the quantity estimate consists in using a graph-based solution.

① Determine the volume of the ACCROPODE™ II units

① Determine the position of the neutral fibre graphically

The neutral fibre (axis) is situated in the middle of the ACCROPODE™ II armour facing, i.e. at $T/2$, T being the thickness of one armour layer. T is a function of the ACCROPODE™ II unit height (cf. Design Guide Table - table 6). The neutral fibre must be determined graphically for each profile/section, and its length must be adjusted depending on the type of toe mound and the edge effects (cf. figure 36 opposite, right). The end result is a neutral fibre length for each section.

② Determine the theoretical surface area on which ACCROPODE™ II units are distributed

Theoretical surface area = sum of the lengths of the neutral fibres multiplied by the length of section to be applied

③ Number of ACCROPODE™ II units

Number of ACCROPODE™ II units = Theoretical surface area x N
Where N , number of units/m²

④ Concrete volume

Concrete volume = theoretical surface area x concrete consumption in m³/m² (cf. Design Guide Table - table 6).

Right - Figure 36: Positioning the neutral fibre graphically

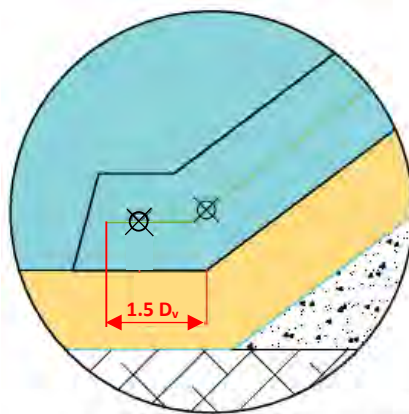
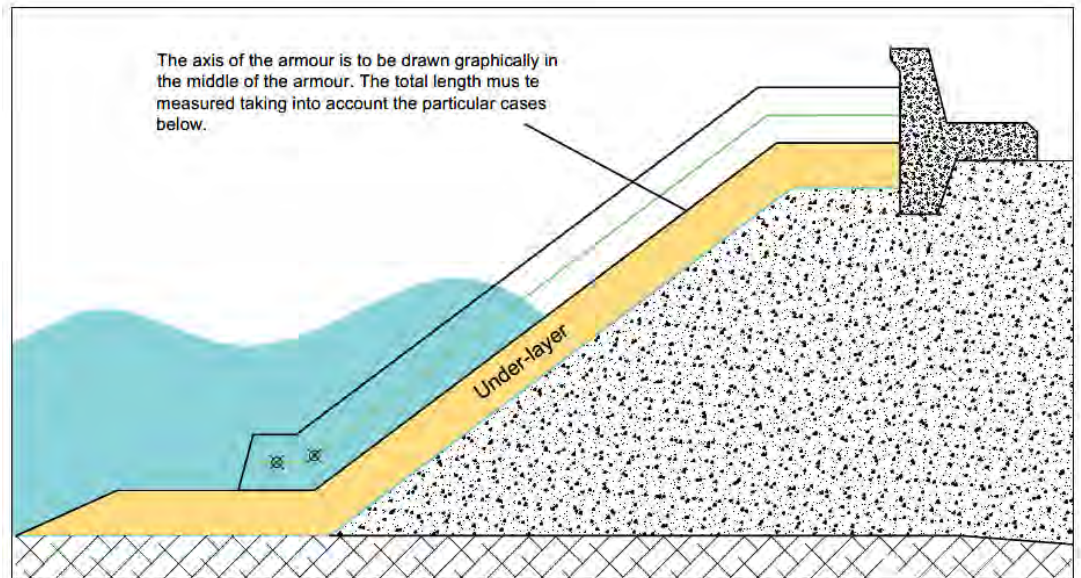

Case of an ACCROPODE™ II toe mound.
Distance between the base of the underlayer and the end of the axis = $1.5 D_v$

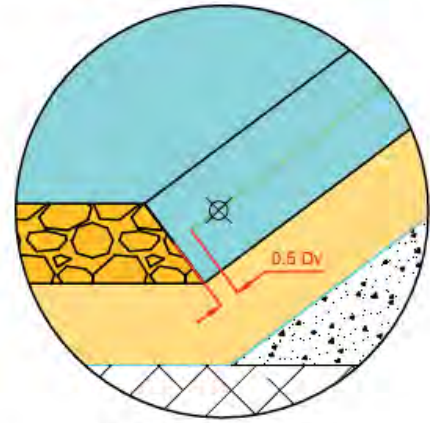

Case of a rockfill toe mound.
Distance between the toe mound and the end of the axis = $0.5 D_v$.

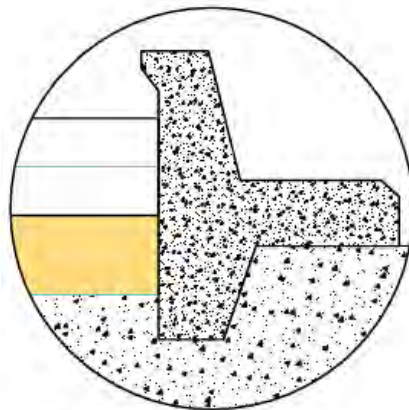

Case of a crown wall.
The axis arrives directly at the wall.

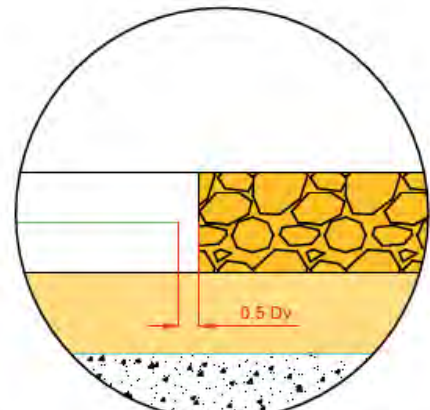

Case of rockfill on the crest.
Distance between the theoretical limit of the rockfill and the end of the axis = $0.5 D_v$.

N.B.: For the D_v of each size, it is advisable to contact CLI in order to obtain the exact value

18. Physical scale modelling

Model units and laboratory assistance

Physical scale model tests are a vital stage of designing a project. They provide an understanding of complex phenomena which cannot be calculated using empirical formulae. These tests are strongly recommended, and often a must in finalising the project.

In the context of the technical assistance related to licensing of the ACCROPODE™ trademark, CLI assists stakeholders during physical scale modelling at any laboratory worldwide. This assistance consists in supplying the model units required and in training the laboratory staff to place them. This training comprises a theoretical component and a practical component, and ensures that the units are placed in accordance with the requirements of the technique. The quality of placing and compliance with the placing density are critical factors that contribute to a successful project outcome. A document summarising the placing methods is systematically supplied to the laboratory whenever a CLI expert provides on-site assistance. The list of available model units can be obtained upon request from CLI either via the Contact page of the website www.concretelayer.com or by sending an email to cli@concretelayer.com.

Below - Figure 37: Physical scale model - 3D - construction phase



Unit stability on a physical scale model

INFORMATION ON THE TESTS

The structure designer must refer to the standards relating to physical scale model tests, including the Hydralab manual, ref [3], which is an essential document. The only information given below is that which provides a greater understanding of the tests relating to ACCROPODE™ II armour units.

The design of an ACCROPODE™ II single-layer armour facing must take a “no damage” criterion based on the design wave conditions into consideration.

The tests are generally performed while incrementing the size of the waves, from the smallest to the largest (e.g. for return periods of 1 year, 5 years, 10 years, 50 years, 100 years or even more if necessary). Tests with an overload wave are strongly recommended, and form part of the usual testing programmes. This wave is generally 120% of the design wave. These tests provide a means of estimating the hydraulic stability reserve of the armour facing. The wave characteristics and periods will be determined by the structure designer.

Water levels have very significant effects on wave behaviour, so it is important to test the structure under the various possible water levels and their combination with design waves. Low water levels often have a direct effect on toe mound stability.

In all cases, special attention must be paid to the toe mound and its foundation. The toe mound must perform its role in all wave conditions. It must not be significantly remodelled, and rockfill must not be thrown against the armour facing.

The damage criteria are determined by the structure designer, as this is the only person who is familiar with the details of the design and the specific site conditions. The designer can obtain assistance from CLI if he or she has questions regarding the unit technique.

Opposite - Figure 38: Physical scale model - 3D - construction phase



USUAL DAMAGE CRITERIA USED WITH PHYSICAL SCALE MODELS

Usual damage criteria for design wave conditions (H_s):

- ✓ No ACCROPODE™ II model units extracted;
- ✓ Limited ACCROPODE™ II unit settlement;
- ✓ Less than 1% permanent oscillation for the ACCROPODE™ II model units;

For a 120% overload of the design wave conditions (120% H_s), the damage criterion is:

- ✓ No ACCROPODE™ II model units extracted.

Below - Figure 39: Photograph of a model breakwater with ACCROPODE™ II units during laboratory testing

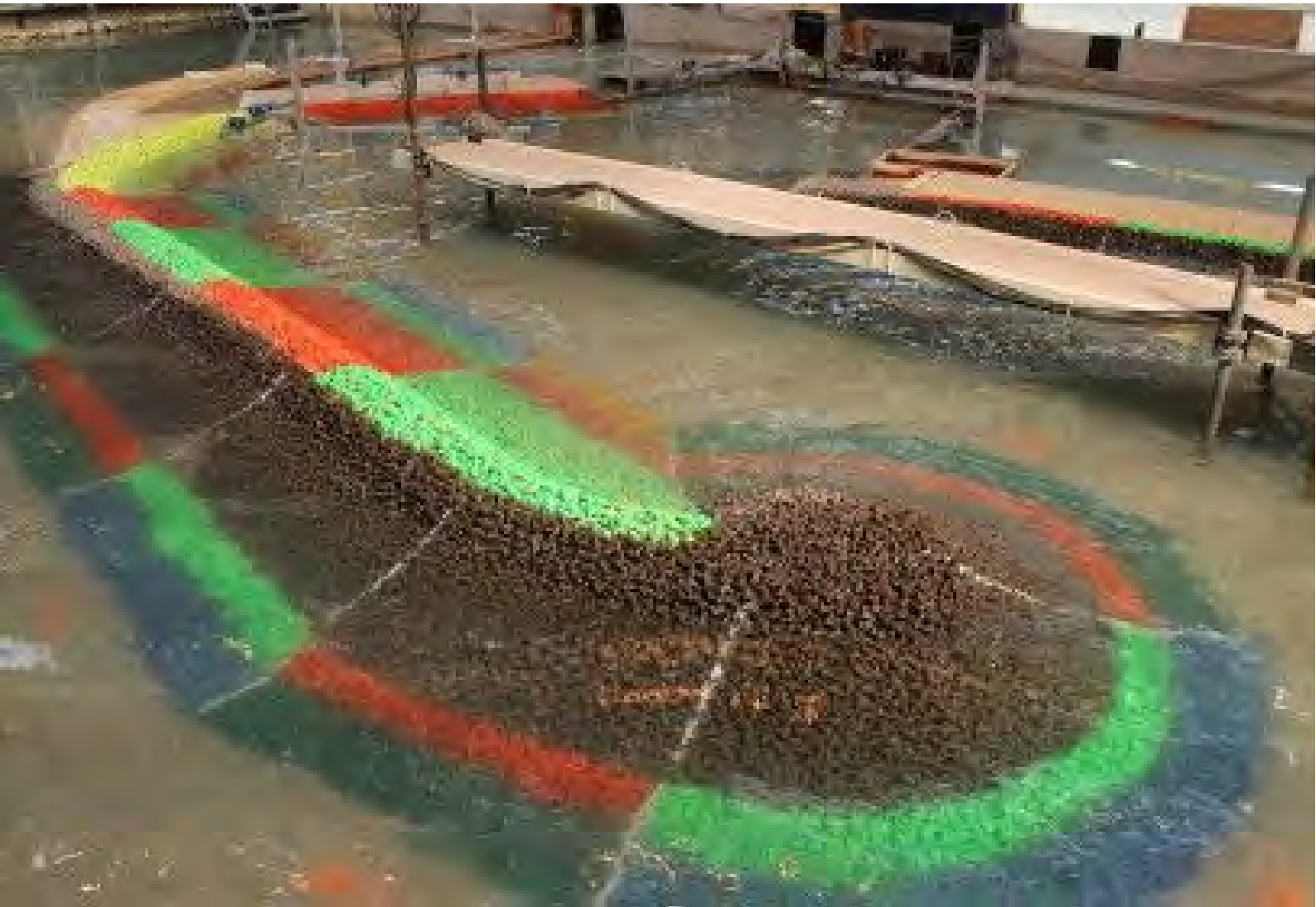

19. Technical assistance

The technical assistance provided by CLI in relation to the sub-licence agreement for the units is a key factor that contributes to a successful project outcome. For this reason, CLI supports the players throughout the various project stages, from the feasibility study through construction and on to monitoring of the structure during its working life. This technical assistance includes the services described below.

Assistance with the structure design phase

ASSISTANCE WITH THE PRELIMINARY DESIGN OF THE ARMOUR FACING

CLI assists the various players during the preliminary conceptual design of the armour facing. The aim of this assistance is to provide the structure designer with general information on the specific features of the armour units. This ensures that the structure designer has the essential basic information required to design the structure without CLI being involved in the actual design process.

PHYSICAL SCALE MODEL TESTS

CLI provides the model units required to perform 2D and/or 3D physical scale model tests in the laboratory chosen by the client. A CLI expert also provides on-site technical assistance at the laboratory in order to provide the placing training required to ensure that ACCROPODE™ II units are used in accordance with the specific rules of the technique.

TENDERING PHASE

During the tendering phases, CLI experts are also available to answer any questions regarding the technique, in the strictest confidence.

Left - Figure 40: On-site technical assistance from a CLI representative





Assistance during the construction phase

AT THE START OF THE WORKS

In the context of the sub-licence agreement, CLI supplies the specifications required by the contractor in charge of the construction works. The services provided include:

- Provision of the Technical Information Document, drawing together the specifications and the experience acquired through the 380 projects completed worldwide.
- Supply of a list of experienced ACCROPODE™ II formwork manufacturers, or of available second-hand formwork;
- Supply of unit shape definition drawings and simplified formwork drawings;
- Review of and advice regarding the methods for fabricating and placing ACCROPODE™ II units;
- Assistance with setting up a quality monitoring system.

DURING THE WORKS

Thanks to a team of specialists dedicated to this technique, CLI:

- Performs site visits dedicated to training and advising the contractor on the works relating to the ACCROPODE™ II units
- Supplies simplified unit placing drawings
- Advises the contractor between site visits on the correct implementation of the ACCROPODE™ II technique. This advice may be provided by email, telephone or video conference. CLI has a video conference room, including scale models, which it uses for remote training.
- Provides the handbook on monitoring and maintaining the ACCROPODE™ II armour facing.

COMPLIANCE CERTIFICATE

On request, following the feasibility study and at the very start of the works, CLI can set up a “Compliance Certificate” procedure to confirm that the ACCROPODE™ II armour facing is constructed in accordance with the specifications and best practice.

Left - Figure 41: On-site technical assistance from a CLI representative

Inspection and maintenance of the structures

All maritime structures must be regularly inspected and maintained right from the end of the construction phase. Rubble-mound breakwaters are no exception to this. Moreover, armour facings of breakwaters are “flexible, ‘living’ structures designed from the outset to undergo deformation and sustain damage throughout their working life” [1] *Fascicule 4*). Single-layer armour facings do not generally require regular replenishment to compensate for the gradual downward movement of units under the effect of gravity. When monitoring is scheduled on a regular basis, the transport of additional materials and large-scale maintenance operations are minimised. In light of the above, however, it is vital to draw up a plan to monitor and maintain the structure on a regular basis and following specific events. The main advantage of these inspections is detecting any change to the armour facing that is likely to worsen. Artificial armour facings are better able to withstand waves than natural rockfill facings. However, they deteriorate more quickly as soon as the initial damage appears. Minor damage must hence be monitored or repaired at a relatively early stage, before it quickly turns into serious damage requiring large-scale repair works.

CLI assists project owners by providing the appropriate documentation and proposing comprehensive armour facing inspection/assessment services performed by its experts and specialists. These inspections are based on the implementation of 3D numerical models with centimetre accuracy that detect all movements irrespective of the underwater visibility conditions. In most cases the intervention of divers is not required.



Figure 42: Upper Zakum project in the United Arab Emirates

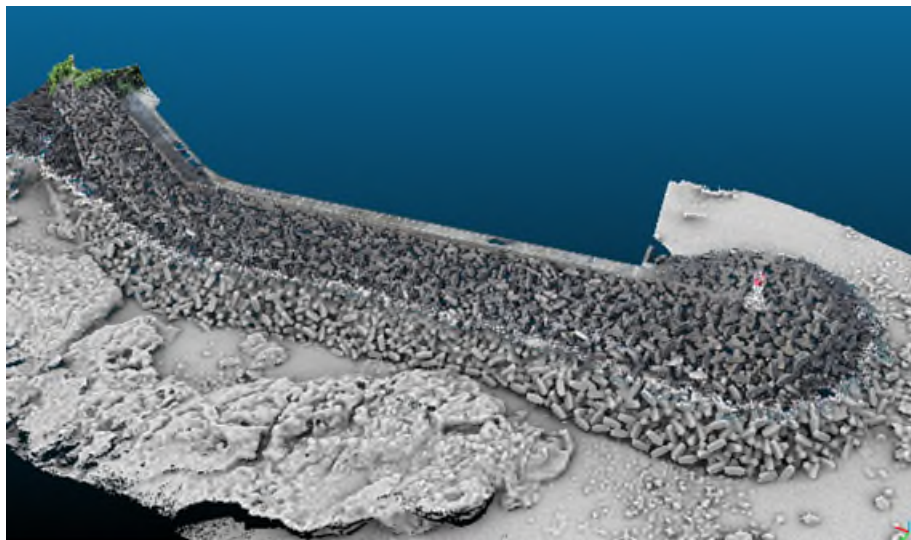

Figure 43: 3D point cloud of an ACCROPODE™ armour facing

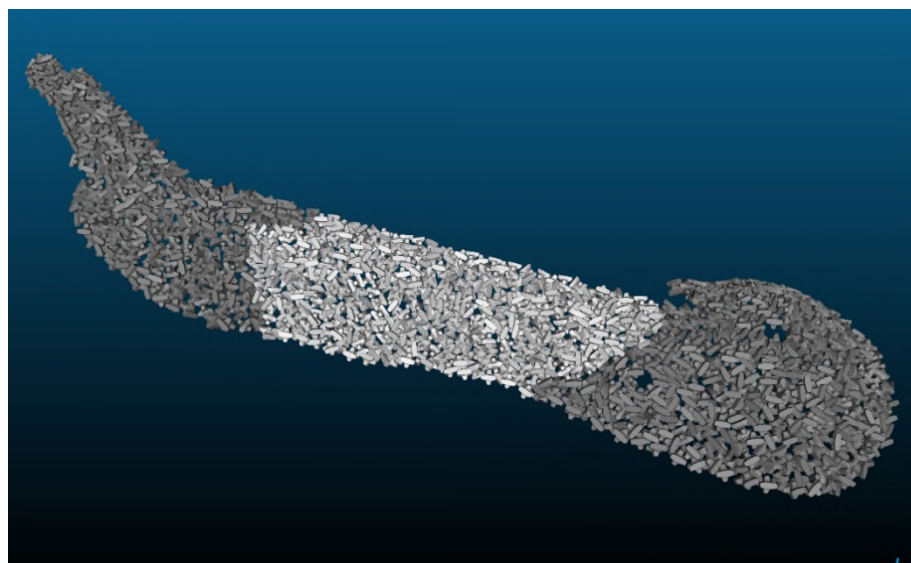

Figure 44: Virtual 3D modelling of armour units

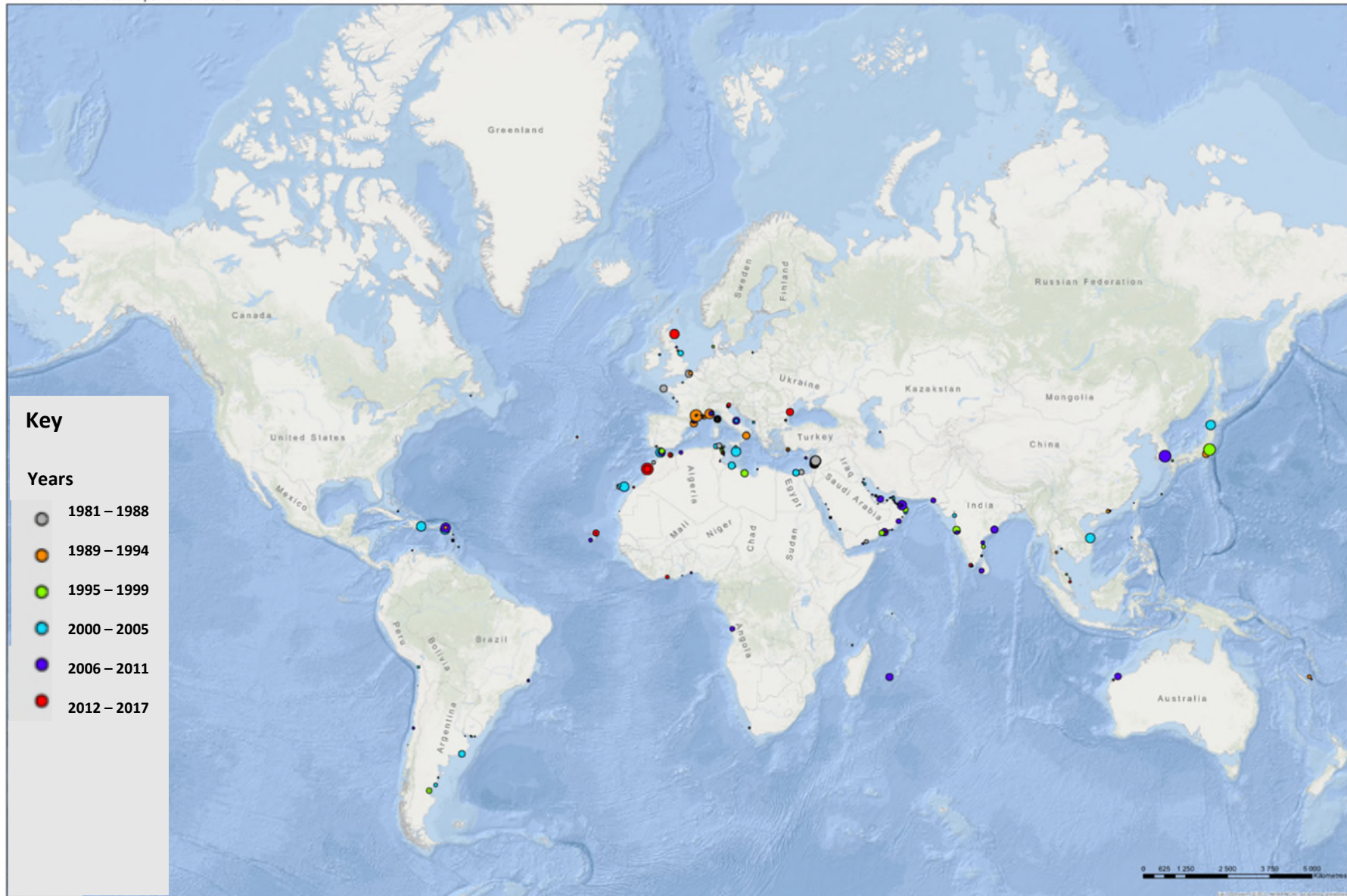

Figure 45: map showing the locations of projects completed by CLI

This new calculator was designed to help you perform preliminary calculations during the early stages of designing your shell.

Accueil - CLI Calculator

CLI Calculator



Step 1/5 Computing parameter

Structure type: Unit type: Armour Slope:

Concrete density (kg/m³): Water density (kg/m³):

Significant wave height (m): Breaking wave:

Bottom level of the armour (m): Upper level of the armour (m):



Step 2/5 Armour unit size estimation

Estimated stability coefficient (K_D): Theoretical volume (m³): Selected volume (m³) Indicate your choice:



Step 3/5 Underlayer

Chosen volume

Selected volume (m³): Unit mass (t): Armour thickness (m):

Unit Height (m):

Chosen underlayer (NLL and NUL)

Standard rockfill NLL (t): <input type="text" value="0.49"/>	Mini possible NLL-30% (t): <input type="text" value="0.35"/>	Maxi possible NLL+30% (t): <input type="text" value="0.64"/>	Select rockfill NLL (t): <input type="text" value="0"/>
Standard rockfill NUL (t): <input type="text" value="0.99"/>	Mini possible NUL-30% (t): <input type="text" value="0.69"/>	Maxi possible NUL+30% (t): <input type="text" value="1.28"/>	Select rockfill NUL (t): <input type="text" value="0"/>

Nb: It is advisable to respect the following ratio $2 < NUL/NLL < 3$



Step 4/5 Results

Theoretical volume	2.9 m³
Selected volume	3 m³
Unit mass	7.05 t
Unit Height	2.07 m
Armour thickness	1.86 m
Armour height	15 m
Packing coefficient Phi Ø	0.645
Number of unit for 100 m²	31.01
Concrete consumption	93.03 m³/100m²
Number of row in the slope	18.25
Underlayer selected (NLL - NUL)	0 - 0 t
Underlayer thickness coefficient K _t	1.15
Underlayer thickness	0 m

The information generated using this computing tool is only indicative and should only be used as an initial approach. Simulations may help clarify some of the main parameters but cannot be used directly to establish the actual basis for the armour design. The Designer remains totally responsible for the complete analysis and definition of the armour design. CLI will provide assistance and advice for all stages, when required, on issues that can influence the final design.

Points of attention and recommendations

NLL (0 t) less than the recommended minimum for this size (0.35 t)
 NUL (0 t) less than the recommended minimum for this size (0.69 t)
 The ratio NUL/NLL (0) does not respect the recommended condition $2 < NUL/NLL < 3$



Step 5/5 Contact for more information

We can guide you to find the best solutions for your job site. Contact us!

Company: Project name: Project country:

Project description:

First name: Last name: E-mail:

Fill in this form and click on the envelope to be contacted. We respect confidentiality and will not share your information with any other company.



20. Calculator

A tool for estimating unit size is available on the CLI website:

www.concretelayer.com/fr/calculateur

It incorporates the variation in K_D of the ACCROPODE II™ units depending on the bed slope and whether the waves break on the trunk section and the roundhead.

This is a preliminary design tool.

Right - Figure 46: CLI calculator available on the website

21. Terms and conditions of use

Intellectual property and rights of use

ACCROPODE™, ECOPODE™ and ACCROBERM™ are registered trademarks and protected internationally by Artelia. CORE-LOC™ is a registered trademark protected internationally the USCOE. The use of any of the technologies stated above requires the prior signature of a sub-licence agreement with CLI.

Warnings relating to this document

This document is intended for specialised readers who have a solid grounding in the dimensional design of rubble-mound breakwaters and maritime hydraulic structures.

The dimensional design of armour facings is a complex process. This document does not claim in any way to constitute the complete source of data or information required to design an armour facing. Users must refer to best practice and the applicable standards in designing their structure. The aim of this document is to provide general information and the initial conditions for the preliminary design of breakwaters with an ACCROPODE™ II single-layer armour facing. This document is not a design handbook and it does not take into consideration all the aspects of designing a breakwater; it only covers the main information relating to or influencing the armour facing. The structure designer remains responsible for the design of the structure in its entirety. It is vital to confirm the structure design with the aid of 2D and 3D physical scale models. CLI or Artelia will not be held liable under any circumstances for direct or consequential damage resulting from use of the content of this document.

A number of online resources to be used in parallel with and as a complement to this document are available on the www.concretelayer.com website.

Left - Figure 47: Lifting an ACCROPODE™ II unit on the project to build a marina in Kuwait



References

[1] CIRIA-CUR-CETMEF The Rock Manual: The use of rock in hydraulic engineering – 2009

[2] Standard EN 13383 Armourstone

[3] Hydralab III Guidelines for physical model testing of breakwaters. Rubble mound breakwaters NA3.1-2 August 2007

Contacts

CLI

4, rue Germaine Veyret - Verner
38130 ECHIROLLES – France

Tel.: +33(0) 476 044 774

Fax: +33(0) 476 044 775

Website: www.concretelayer.com

Email: cli@concretelayer.com





ACCROPODE™ II

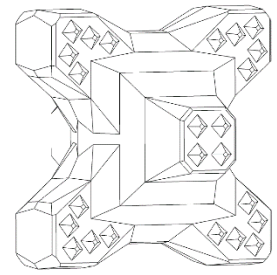

ACCROPODE™ I

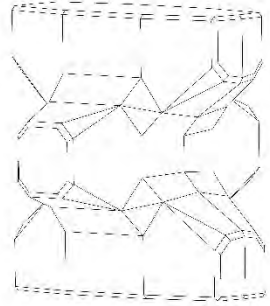

CORE-LOC™

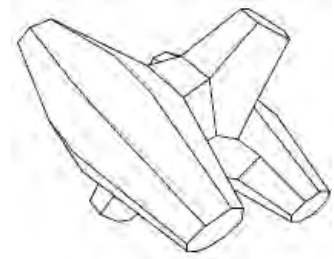

ECOPODE™

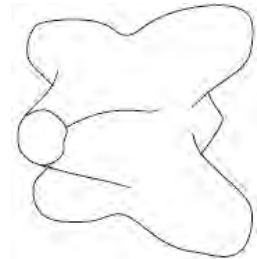

ACCROBERM™ I

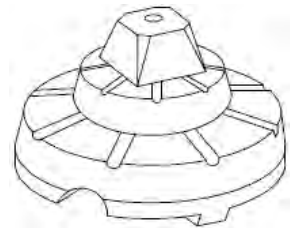

ACCROBERM™ II

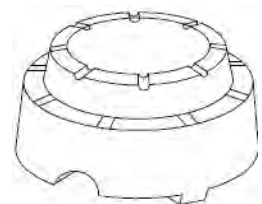



CLI
Concrete Layer Innovations